

A3-1585L

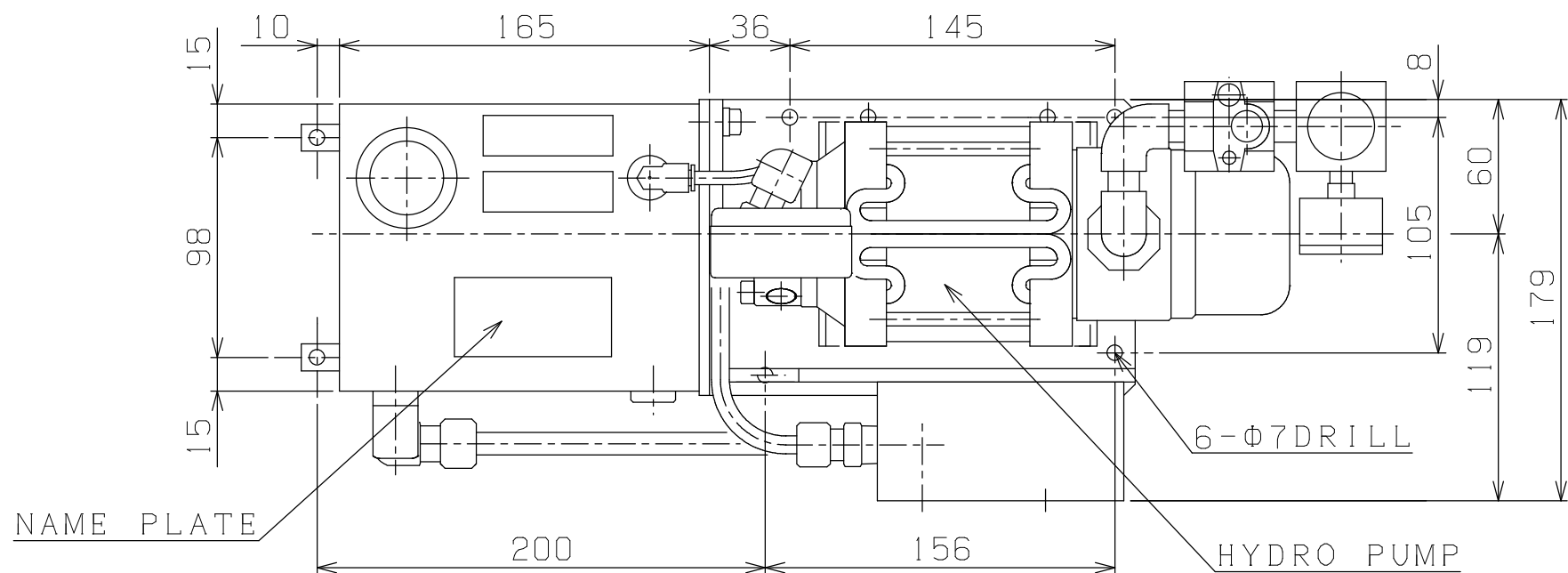

SPECIFICATION	
MAX. PRESSURE (OIL)	40 MPa (400kgf/cm ²)
MAX. PRESSURE (AIR)	0.8 MPa (8.0kgf/cm ²)
AIR CAPACITY	1.2m ³ /min.
INCREASING RATIO	1:50
DISCHARGE	HYDRO PUMP PERF. CURVE
WORKING FLUID	ISO VG15~46
TANK CAPACITY	MAX.=2.4L EFFECTIVE=1.5L
WEIGHT (APPROX)	14 kg

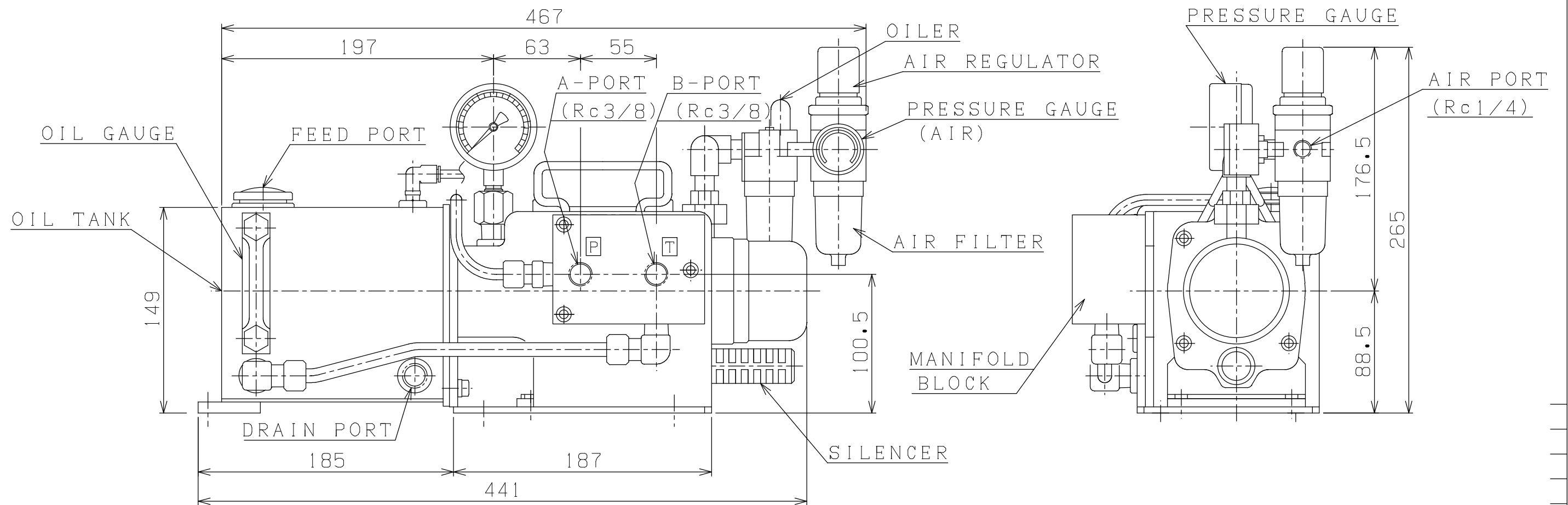

G2-1・MHPUユニット・外・2L・MHP50

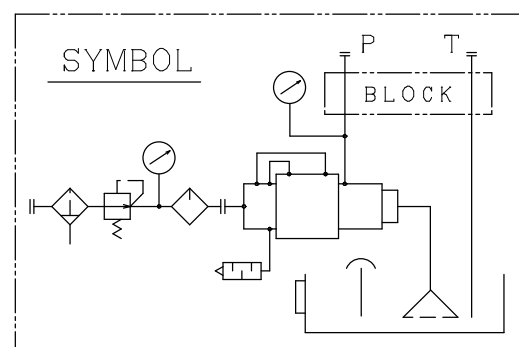

PLAN RECORD		基本仕上	MARK	PARTICULAR	QUAN	MATERIAL	SIZE	WEIGHT	REMARK
寸法許容差		C H I E F			MHPU50-N2L				
区分	許容差	H E A D			HYDRO PUMP UNIT				
1 ~ 4	±0.1	CHECKED BY			DRAWING NO. A3-1585L				
5 ~ 16	±0.2	DRAWN BY							
17 ~ 63	±0.3	DATE DRAWN							
64 ~ 250	±0.5	SCALE 1/3							
250~1000	±0.8								

RIX リックス株式会社 RIX CORPRATION

記号
400S
100S
25S
6.3S
0.8S