

A 3 - 1 5 8 5 N

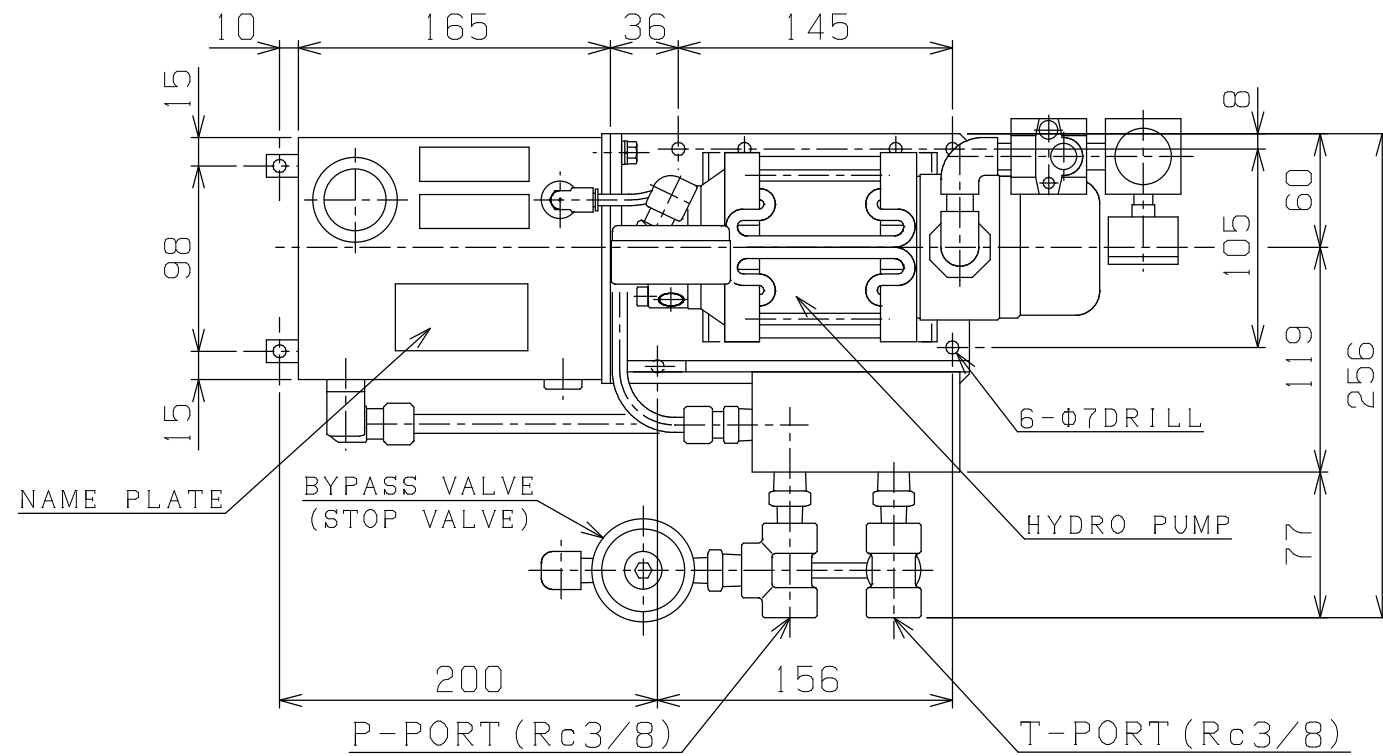

SPECIFICATION	
MAX. PRESSURE (OIL)	40 MPa (400kgf/cm <sup>2</sup> )
MAX. PRESSURE (AIR)	0.8 MPa (8.0kgf/cm <sup>2</sup> )
AIR CAPACITY	1.2m <sup>3</sup> /min.
INCREASING RATIO	1:50
DISCHARGE	HYDRO PUMP PERF. CURVE
WORKING FLUID	ISO VG15~46
TANK CAPACITY	MAX.=2.4L EFFECTIVE=1.5L
WEIGHT (APPROX)	14 kg G

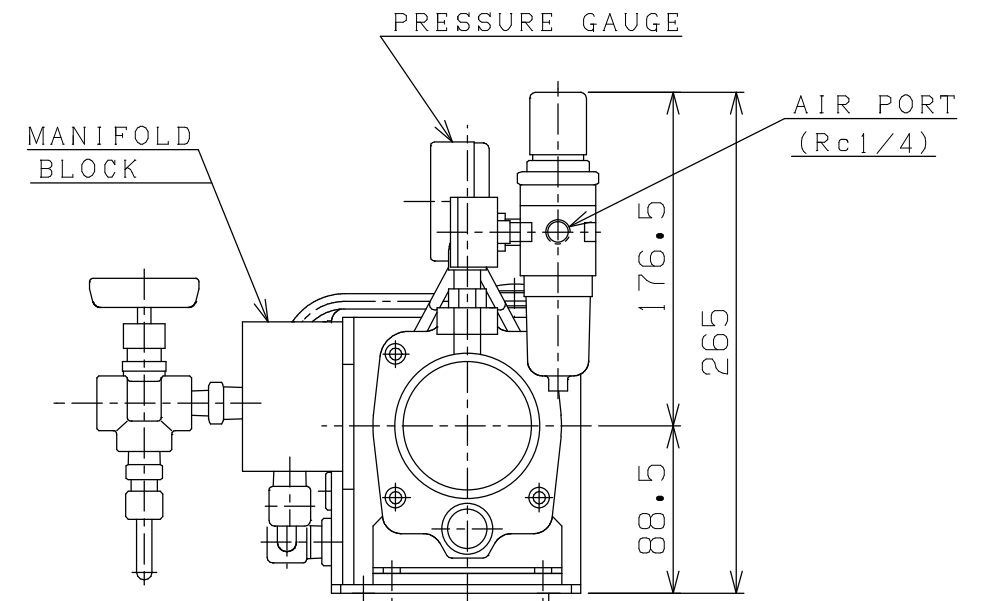
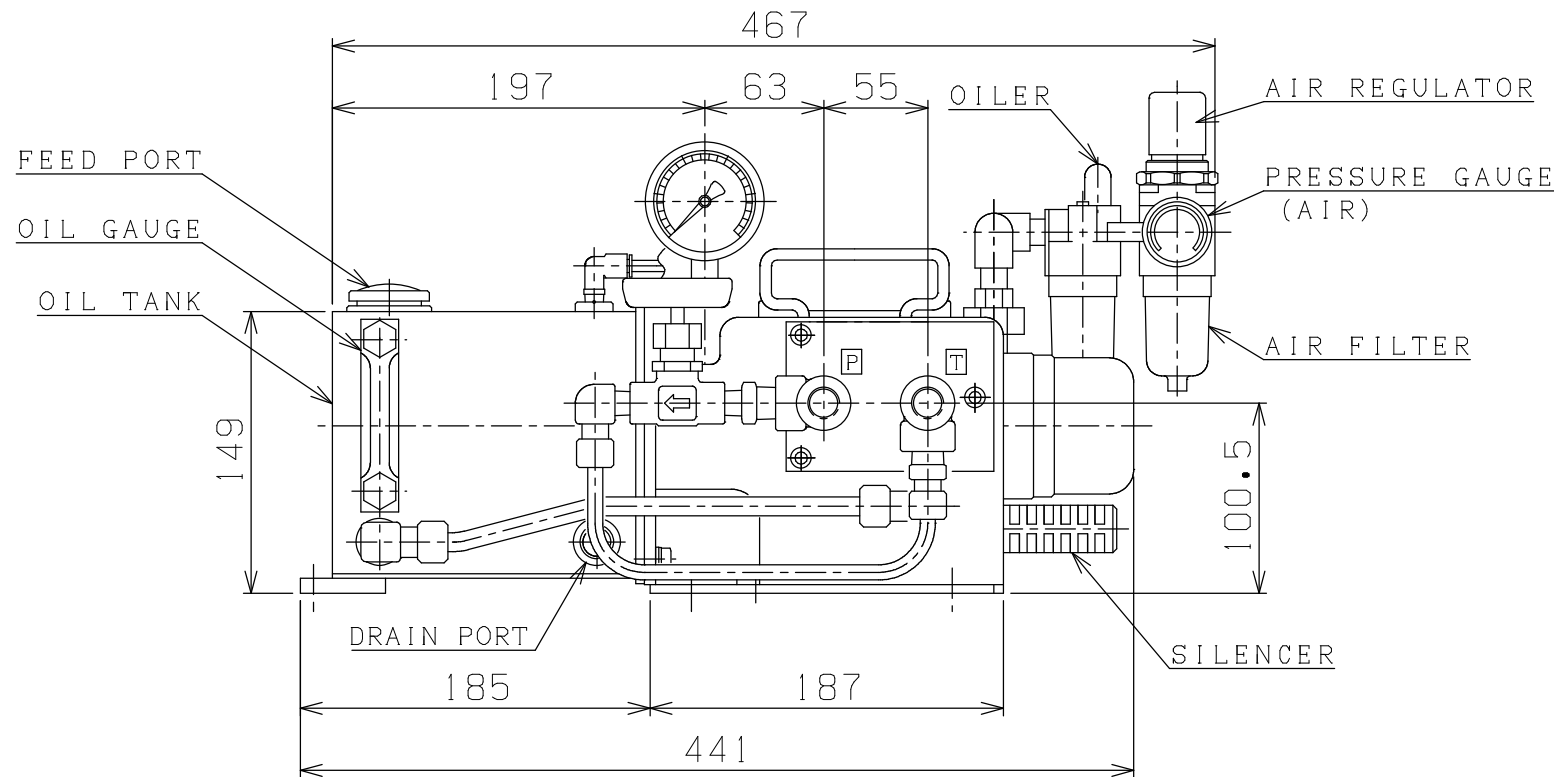

G2-1・MHPUユニット・外・2L・MHP50

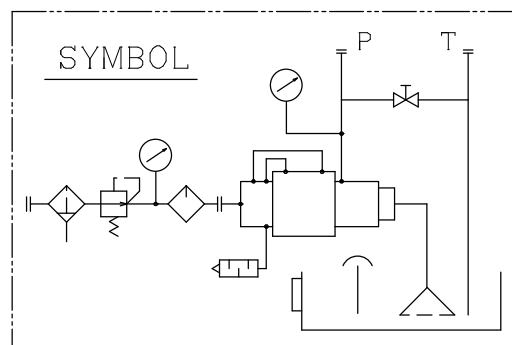

PLAN RECORD		基本仕上	MARK	PARTICULAR	QUAN	MATERIAL	SIZE	WEIGHT	REMARK
寸法許容差		C H I E F	MHPU50-B2L						
区分	許容差	H E A D	HYDRO PUMP UNIT						
1 ~ 4	±0.1	CHECKED BY	DRAWING NO. A 3 - 1 5 8 5 N						
5 ~ 16	±0.2	DRAWN BY							
17 ~ 63	±0.3	DATE DRAWN							
64 ~ 250	±0.5	SCALE	1 / 4						
250~1000	±0.8	 リックス株式会社 RIX CORPRATION							

記号  
400S  
100S  
25S  
6.3S  
0.8S